



UNIVERSITY OF CAMBRIDGE INTERNATIONAL EXAMINATIONS
International General Certificate of Secondary Education

CANDIDATE
NAME

CENTRE
NUMBER

--	--	--	--	--

CANDIDATE
NUMBER

--	--	--	--



PHYSICS

0625/31

Paper 3 Extended

October/November 2011

1 hour 15 minutes

Candidates answer on the Question Paper.

No Additional Materials are required.

READ THESE INSTRUCTIONS FIRST

Write your Centre number, candidate number and name on all the work you hand in.

Write in dark blue or black pen.

You may use a pencil for any diagrams, graphs or rough working.

Do not use staples, paper clips, highlighters, glue or correction fluid.

DO NOT WRITE IN ANY BARCODES.

Answer **all** questions.

You may lose marks if you do not show your working or if you do not use appropriate units.

Take the weight of 1 kg to be 10 N (i.e. acceleration of free fall = 10 m/s^2).

At the end of the examination, fasten all your work securely together.

The number of marks is given in brackets [] at the end of each question or part question.

This document consists of **15** printed pages and **1** blank page.



1 (a) Define *acceleration*. Explain any symbols in your definition.

.....
[1]

(b) Fig. 1.1 shows a graph of speed against time for a train. After 100s the train stops at a station.

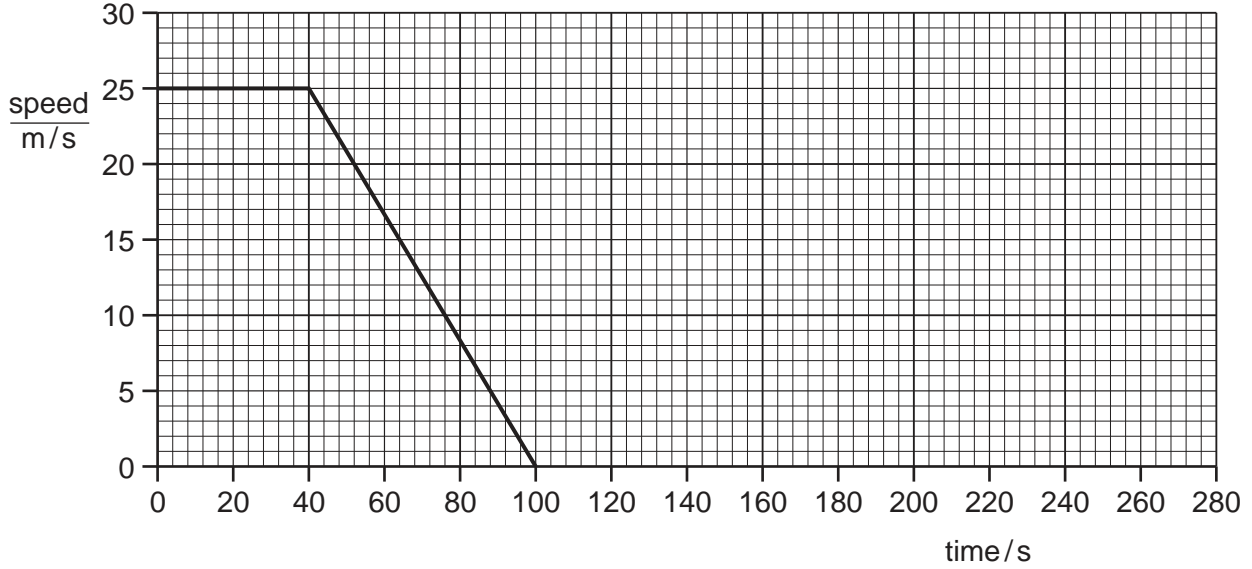

Fig. 1.1

(i) For the time interval between 40s and 100s, calculate the distance travelled by the train.

distance =[2]

(ii) The train stops for 80s, then accelerates to 30m/s with an acceleration of 0.60m/s². It then travels at constant speed.

Complete the graph for the interval 100s to 280s, showing your calculations in the space below.

[5]

[Total: 8]

3 (a) State the two conditions required for the equilibrium of a body acted upon by a number of forces.

1.

 2.
 [2]

(b) Fig. 3.1 shows a diagram of an arm with the hand holding a weight of 120 N.

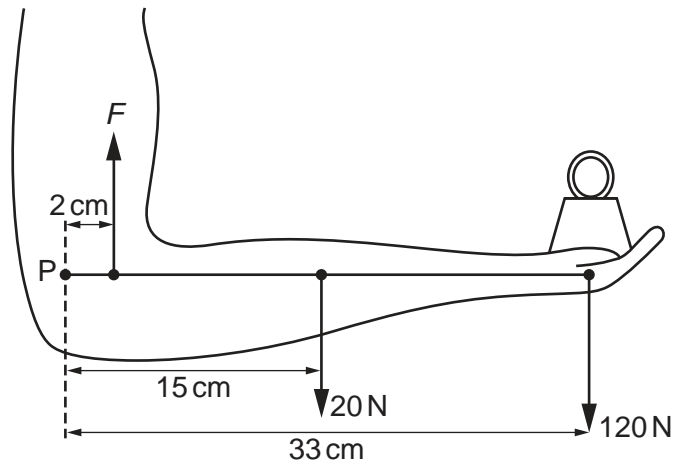

Fig. 3.1

The 20 N force is the weight of the forearm, acting at its centre of mass. F is the force in the muscle of the upper arm. P is the point in the elbow about which the arm pivots. The distances of the forces from point P are shown.

(i) By taking moments about point P , calculate the force F .

force $F =$ [3]

(ii) A force acts on the forearm at point P . Calculate this force and state its direction.

force =

direction = [2]

[Total: 7]

- 4 (a) Complete Fig. 4.1 to show a simple mercury barometer. Insert the correct labels in the boxes. Label with the letter h the measurement required to calculate the pressure of the atmosphere.

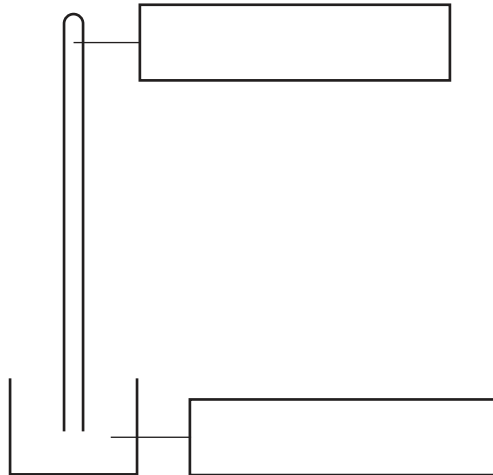

[3]

Fig. 4.1

- (b) The value of h taken using this barometer is 0.73 m. The density of mercury is 13600 kg/m^3 . Calculate the value of the atmospheric pressure suggested by this measurement. Use $g = 10 \text{ m/s}^2$.

atmospheric pressure =[2]

- (c) Standard atmospheric pressure is 0.76 m of mercury. Suggest a reason why the value of h in (b) is lower than this.

.....
[1]

[Total: 6]

5 (a) Equal volumes of a gas held at constant pressure, a liquid and a solid undergo the same temperature rise.

(i) State which of the three, solid, liquid or gas,

1. expands the most,

2. expands the least.

(ii) Explain why the pressure of the gas must be kept constant for this comparison.

.....
.....[2]

(b) Fig. 5.1 shows an alcohol thermometer.

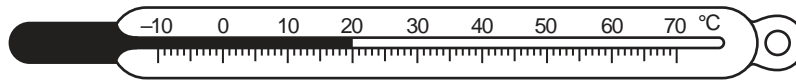

Fig. 5.1

(i) State two properties of alcohol which make it suitable for use in a thermometer.

1.
.....
2.
.....[2]

(ii) State **two** changes to the design of this thermometer which would make it more sensitive.

1.
.....
2.
.....[2]

(c) Explain why it is an advantage for the glass surrounding the alcohol in the bulb of the thermometer to be very thin.

.....
.....[1]

[Total: 7]

- 6 (a) Fig. 6.1 shows the position of layers of air, at one moment, as a sound wave of constant frequency passes through the air. Compressions are labelled C. Rarefactions are labelled R.



Fig. 6.1

- (i) State how Fig. 6.1 would change if

1. the sound had a higher frequency,

.....[1]

2. the sound were louder.

.....

.....

.....[2]

- (ii) On Fig. 6.1, draw a line marked with arrows at each end to show the wavelength of the sound. [1]

- (b) In an experiment to measure the speed of sound in steel, a steel pipe of length 200m is struck at one end with a hammer. A microphone at the other end of the pipe is connected to an accurate timer. The timer records a delay of 0.544s between the arrival of the sound transmitted by the steel pipe and the sound transmitted by the air in the pipe.

The speed of sound in air is 343 m/s. Calculate the speed of sound in steel.

speed of sound in steel =[3]

[Total: 7]

- 7 (a) Fig. 7.1 shows a ray of monochromatic red light, in air, incident on a glass block at an angle of incidence of 50° .

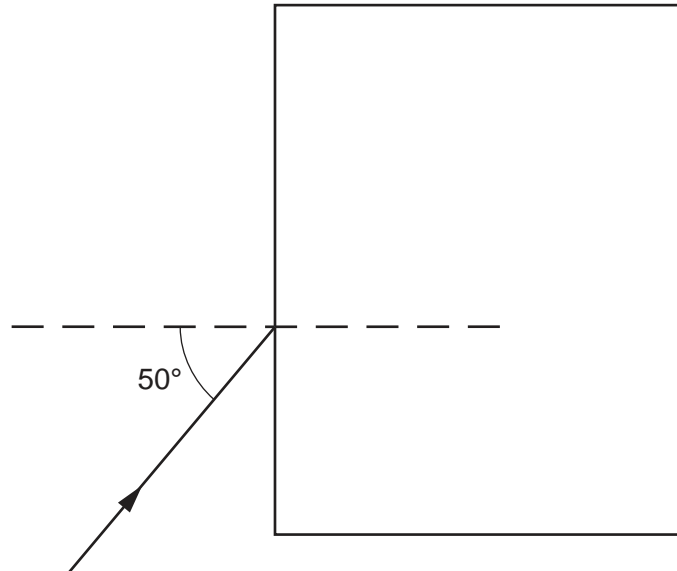

Fig. 7.1

- (i) State what is meant by *monochromatic* light.

.....[1]

- (ii) For this red ray the refractive index of the glass is 1.52. Calculate the angle of refraction for the ray.

angle of refraction =[2]

- (iii) Without measuring angles, use a ruler to draw the approximate path of the ray in the glass block and emerging from the block. [2]

(b) The red ray in Fig. 7.1 is replaced by a ray of monochromatic violet light. For this violet ray the refractive index of the glass is 1.54. The speed of light in air is 3.00×10^8 m/s.

(i) Calculate the speed of the violet light in the glass block.

speed =[2]

(ii) Use a ruler to draw the approximate path of this violet ray in the glass block and emerging from the block. Make sure this path is separated from the path drawn for the red light in (a)(iii). Mark both parts of this path with the letter V. [2]

[Total: 9]

- 8 (a) In Fig. 8.1, a magnet is moving towards one end of a solenoid connected to a sensitive centre-zero meter. During this movement a current is induced in the solenoid.

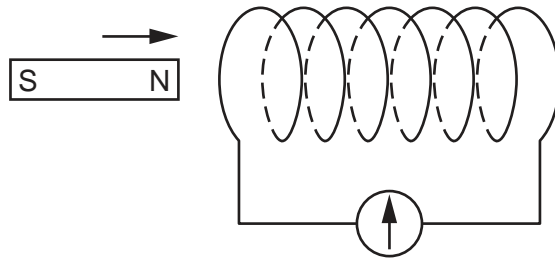

Fig. 8.1

Suggest **three** possible changes to the system in Fig. 8.1 that would increase the induced current.

1.
2.
3.[3]

- (b) Fig. 8.2 shows a transformer. P is the primary coil. S is the secondary coil. The coils are wound on an iron core.

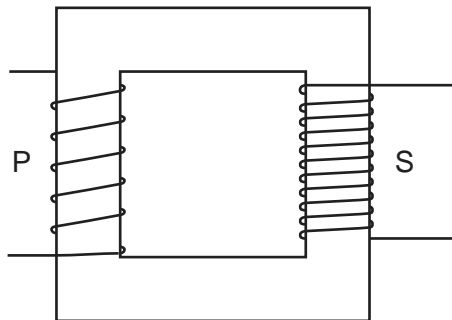

Fig. 8.2

P has 200 turns and S has 800 turns. The e.m.f. induced across S is 24V. The current in S is 0.50A. The transformer operates with 100% efficiency.

Calculate

(i) the voltage of the supply to P,

voltage =[2]

(ii) the current in P.

current =[2]

[Total: 7]

- 9 The graphs in Fig. 9.1 show the relation between the current I and the potential difference V for a resistor and a lamp.

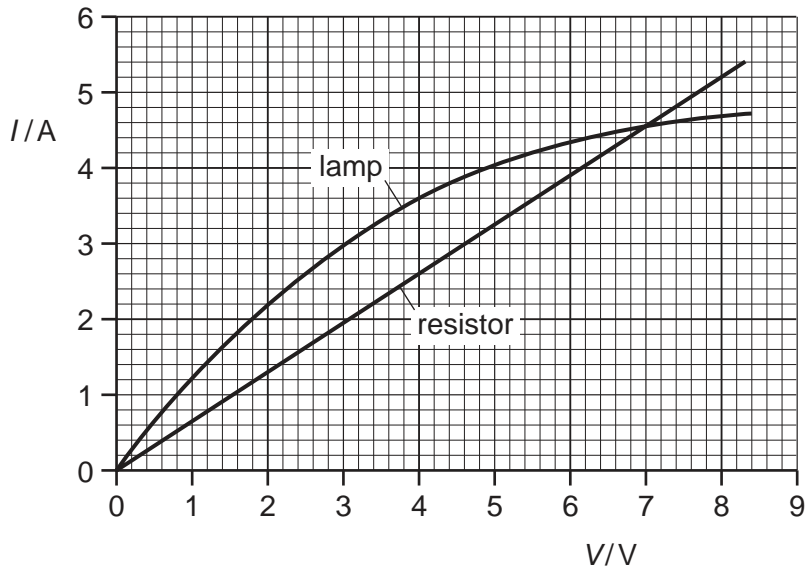

Fig. 9.1

- (a) (i) Describe how, if at all, the resistance varies as the current increases in
1. the resistor,
 2. the lamp.[2]
- (ii) State the value of the potential difference when the resistor and the lamp have the same resistance.

potential difference =[1]

- (b) The two components are connected **in parallel** to a supply of e.m.f. 4.0V. Calculate the total resistance of the circuit.

total resistance =[4]

[Total: 7]

10 (a) In Fig. 10.1, A is a 1000Ω resistor, C is a transistor, and D is a lamp. S is a 9V supply.

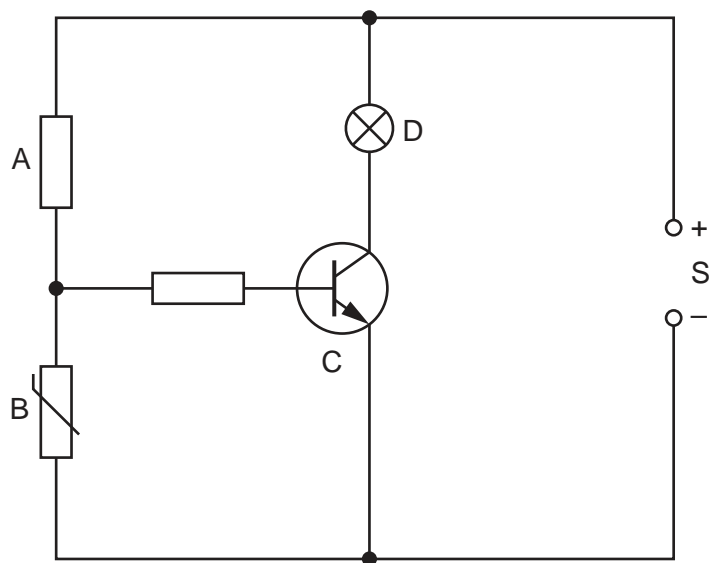

Fig. 10.1

(i) Name the component labelled B.

.....[1]

(ii) At 20°C the resistance of B is 800Ω .
At 100°C the resistance of B is 25Ω .

In terms of the p.d. across B, explain what happens in the circuit as the temperature varies from 20°C to 100°C .

.....

[4]

(b) Suggest a practical use for this circuit.

.....
[1]

[Total: 6]

11 Fig. 11.1 shows the main components of a cathode-ray oscilloscope.

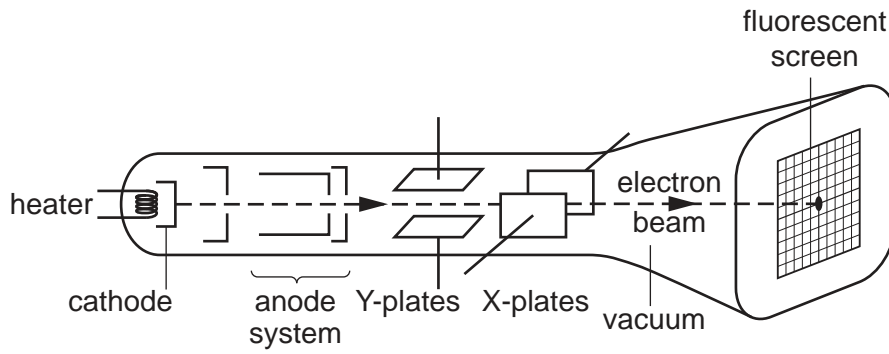

Fig. 11.1

(a) State the purpose of

(i) the heater,

.....

(ii) the cathode,

.....

(iii) the anode system.

.....

[4]

(b) Without deflection, the electron beam produces a spot at the centre of the fluorescent screen. A deflection of the spot towards the top of the screen is required.

(i) Describe how the Y-plates can be used to bring about this deflection.

.....
.....

(ii) Fig. 11.2 shows the Y-plates.



Fig. 11.2

On Fig. 11.2, sketch the pattern of the electric field produced between the plates.

[4]

[Total: 8]

BLANK PAGE

Permission to reproduce items where third-party owned material protected by copyright is included has been sought and cleared where possible. Every reasonable effort has been made by the publisher (UCLES) to trace copyright holders, but if any items requiring clearance have unwittingly been included, the publisher will be pleased to make amends at the earliest possible opportunity.

University of Cambridge International Examinations is part of the Cambridge Assessment Group. Cambridge Assessment is the brand name of University of Cambridge Local Examinations Syndicate (UCLES), which is itself a department of the University of Cambridge.